



INSPIRED SOLUTIONS



FIRST IMPRESSIONS

LOBBY
RECEPTION
CENTERS



INFORMATION
CENTERS



PATIENT
CHECK IN

NEAT & ORDERLY

LABORATORY
SPACES TO FIT
YOUR NEEDS



PHARMACY
& LAB
ORGANIZATION

COUNTERS
& FILING



CAREFUL CONSIDERATION



STORAGE & COUNTERS CONFIGURED TO YOUR SPECS

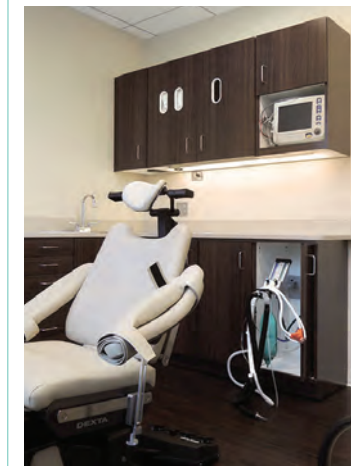

EVERYTHING TO SUPPORT PATIENT CARE



RENDEZVOUS POINT

LOCKERS
& SECURE
SPACES



SCHOOLS
& GYMS



KEEP SAFE & SECURE

1 FILL OUT A QUOTE REQUEST FORM, AVAILABLE AT AMCASE.COM

2 SUBMIT DESIGN INTENT & SUPPORTING INFO (SKETCHES, CAD FILES ETC)

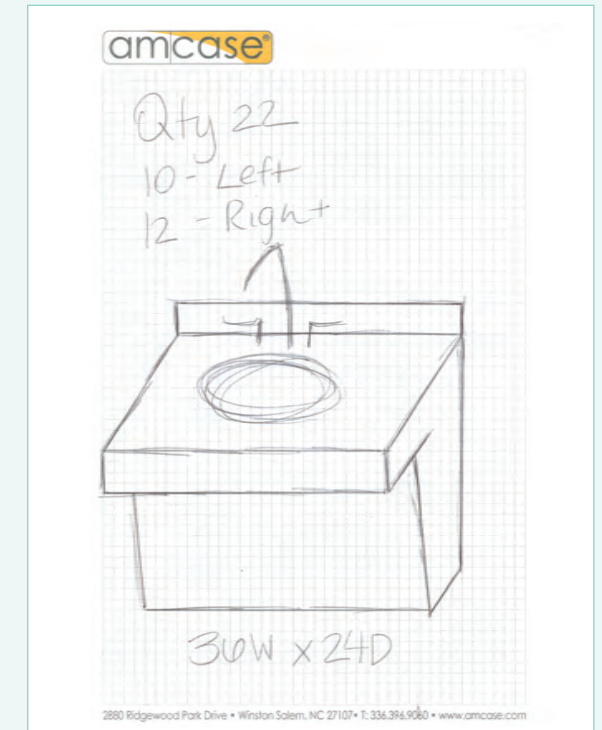

3 LINE DRAWINGS ARE REVIEWED AND APPROVED

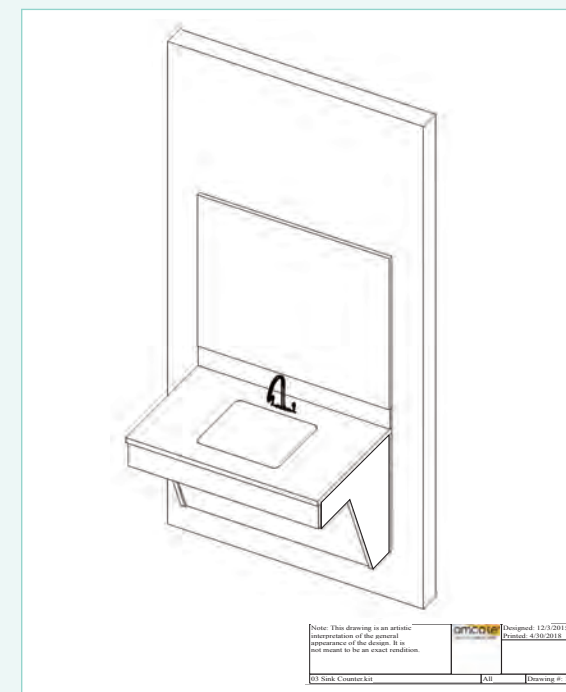

4 AMCASE MANUFACTURES YOUR FINISHED PRODUCT



Moveable. Reconfigurable. Reusable.

7 Year Warranty

7 Year Deprecation

10 K Standard Modular Components

Meets or Exceeds ANSI/BIFMA Standards

USGBS Standards Available

State and Federal Contracts



2880 Ridgewood Park Dr
Winston Salem, NC 27107

email: sales@amcase.com

phone: 888.396.9060

fax: 336.499.5992